

Company		Contact	
Street		Telephone	
City, ZIP		Fax	
Country		e-mail	

Machine type	
Srew-Ø	
Material to be processed (if known)	

Nozzle adapter with external thread

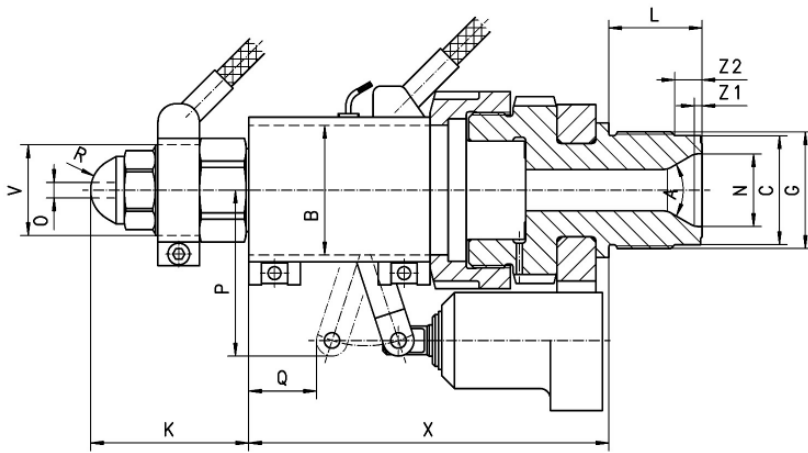

Dimensions	Key to drawing
G	Connecting thread on adapter or cylinder
L	Thread length incl. length of centering device
N	Inlet diameter of adapter or cylinder
C	Centering diameter of adapter or cylinder
Z2	Length of centering device
R	Tip profile (radius or angle)
O	Orifice
A	Angle
Z1	Cylindrical length

Standard dimensions in mm

	L10	L20	L30
B	Ø 45	Ø 50	Ø 70
P	62	64	88
Q	22	26	40
V	Ø 30	Ø 35	Ø 55
X	134	139	202

Nozzle size

- L10** (500 cm³/sec with PS, screw-Ø up to 30mm, orifice max. 4mm)
- L20** (1500 cm³/sec with PS, screw-Ø 20-120mm, orifice max. 7mm)
- L30** (3700 cm³/sec with PS, screw-Ø from 80mm, orifice max. 11mm)

K = Option Tip length

- L10 TL=16mm (Standard) TL=50mm
- L20 TL=25mm (Standard) TL=60mm TL=100mm
- L30 TL=35mm (Standard) TL=80mm TL=120mm

- Option glass fibre application** (special needle guide)
- Option 1-hole needle** (For long glass fibres)

Options accessories

- Actuator** Pneumatic Hydraulic
- Body heater band** 240V, cable length 1,5m
- Tip heater band** 240V, cable length 1,5m
- Thermocouple** J-Type, cable length 1,5m, thread M8x1

Customer information

We need additional information (e.g. drawing, sample) for requirements that deviate from our standard information sheet. Our customer service shall be pleased to advise you.

Date / Signature

⇒ www.system-eng.ch
 ⇒ info@system-eng.ch
 ⇒ Fax: +41 (0)62 295 5270